



# Nastran

Advanced Finite Element Analysis

2. **Advanced Finite Element Analysis**

3. **25 Key Features of NEi Nastran**

4. **10 Reasons You Should Be Using NEi Nastran**

6. **NEi Nastran Analysis Types**



# Advanced Finite Element Analysis

## NEi Nastran

NEi Nastran is a powerful, general purpose Finite Element Analysis (FEA) tool with an integrated graphical user interface and model Editor which is used to analyze linear and nonlinear stress, dynamics, and heat transfer characteristics of structures and mechanical components. It represents the latest in FEA technology with some of the fastest solvers on the market along with accurate solutions that have been trusted for nearly 20 years by companies in all industries. NEi Nastran is available on a wide variety of platforms including 32-bit and 64-bit Windows and Linux operating systems.

## Modeler

Femap® is a Windows-native pre- and post-processor used by engineering organizations worldwide to model various products, processes, and systems. Its graphical user interface provides streamlined, direct access to all Femap functionality. This version runs on 32-bit and 64-bit operating systems on Windows XP, Vista and Windows 7. The V10.1 release focuses more on pre-processing and meshing, thus it includes significant new functionality like 3D solid and surface meshers, interactive mesh generation and verification, new robust mesh improvement tools. There are new API methods added, and as always, Femap is tightly integrated with NEi Nastran and also provides integration to a wide range of industry-standard structural and thermal solvers.

## Editor

The NEi Editor is an industry unique tool that gives engineers greater control over their Nastran FEA models and results. Features such as advanced editing, context-sensitive input, and dynamic help greatly increase productivity and results reliability from the start. Built-in tools such as the trade study generator and parameter optimization give users quick insight into the effects of design changes. Real-time results are displayed through an integrated results processor allowing users to visualize results as they are generated during the solution sequence. These features combined make the NEi Editor an indispensable tool for designers and analysts alike.

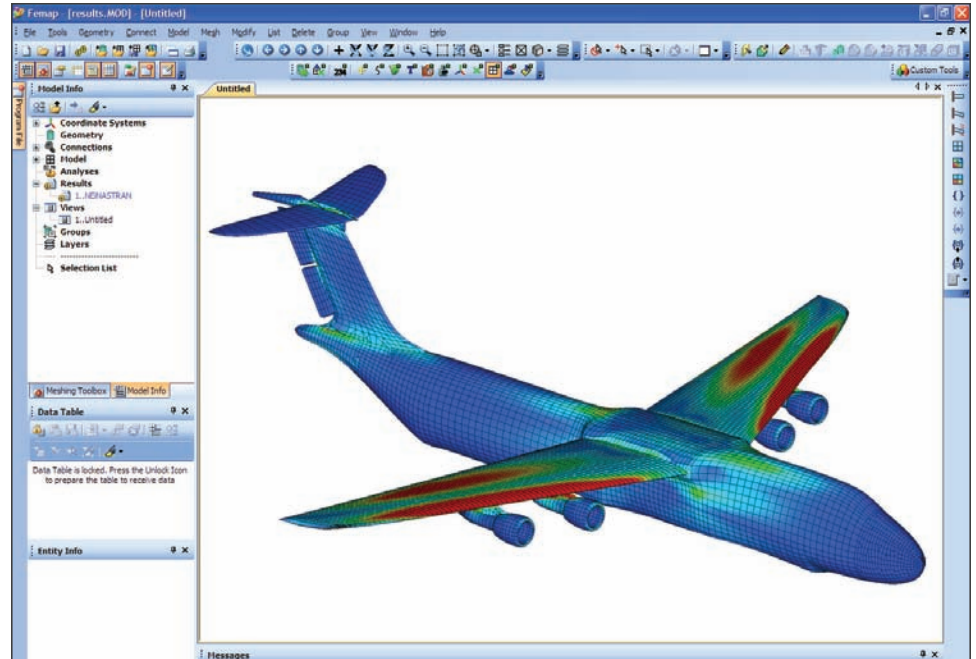

*NEi Nastran analysis within the Femap modeler*

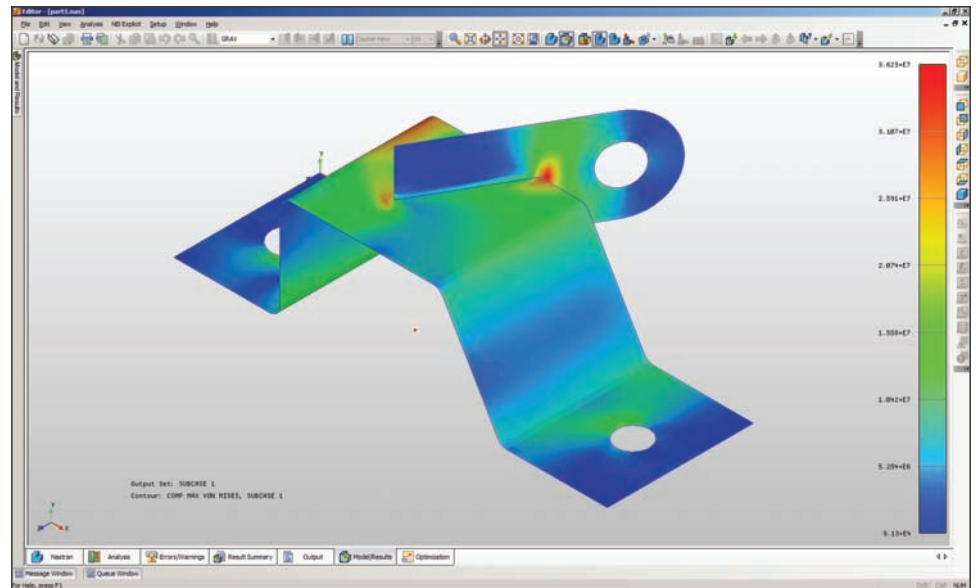

*The industry unique NEi Editor*

## Solver

NEi Nastran uses the latest in solver technology providing fast results for the largest and most complex FEA models. Four linear solvers (PCGLSS, PSS, VSS, and VIS) and two eigensolvers (LANCZOS and SUBSPACE) are included. The PCGLSS (Preconditioned Conjugate Gradient Linear System Solver) is an advanced parallel iterative solver licensed

from CA&SI and used in many other leading FEA products. The PSS solver is an extremely fast parallel direct solver and is highly scalable for multi-cpu/core processors. The VSS (Vector Sparse Solver) and VIS (Vector Iterative Solver) are based on NASA developed technology and have been enhanced to provide better performance and accuracy.

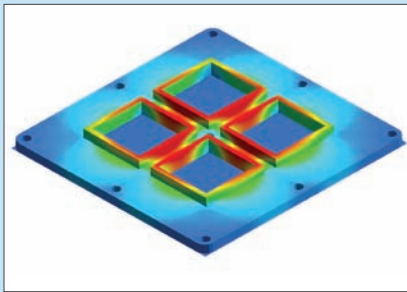

Boeing Space Systems used NEi Nastran to design and analyze this high temperature super alloy assembly. The assembly, which will be used to contain flight experiments mounted on the underside of NASA's X-34 Reusable Space Vehicle, is subjected to aero-thermal heating on vehicle re-entry. Temperatures accessed directly from the heat transfer solution were used to perform stress analysis using the same statics and dynamics model. Several critical design changes were made as a result of this coupled analytical approach, which ultimately resulted in the successful arcjet test at NASA Ames Research Center.

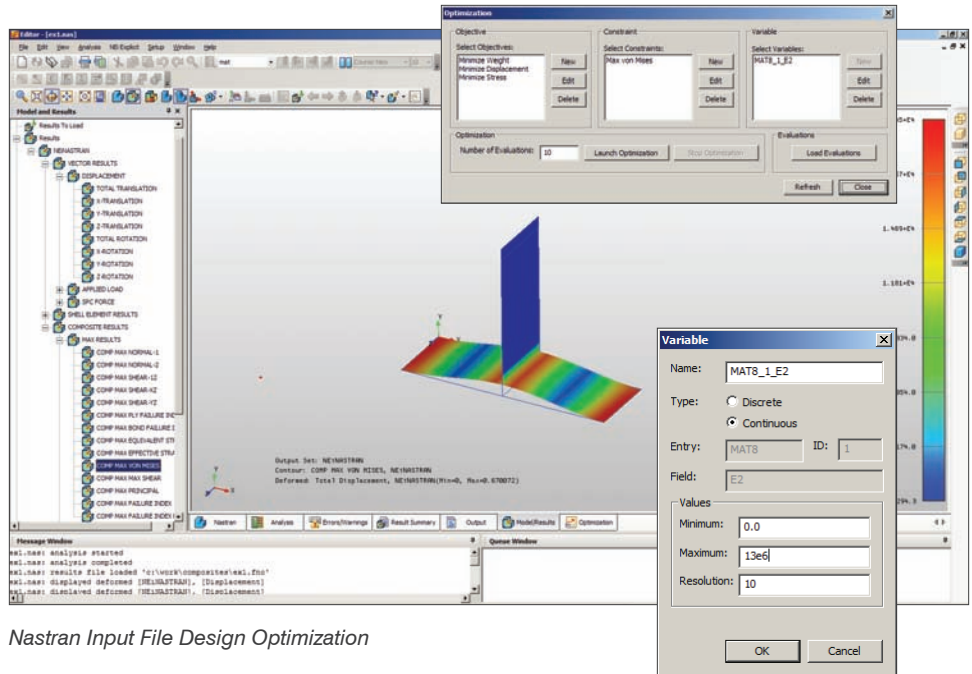

Nastran Input File Design Optimization

## 25 Key Features of NEi Nastran

1. Micromechanics Based Composite Laminate Failure Analysis
2. Advanced Composites Ply Failure Criteria (LaRC02, Puck, MCT)
3. Nonlinear Progressive Ply Failure Analysis (PPFA™)
4. Advanced 3D Layered Composite Analysis
5. NEi Nastran Editor GUI
6. Shape and Parameter Design Optimization
7. Automated Analysis Report Generation
8. Multiaxial and Vibration Fatigue
9. Linear Surface Contact
10. Nonlinear Surface Contact
11. Automated Surface Contact Generation (ASCG™)
12. Automated Edge Contact Generation (AECG™)
13. Automated Impact Analysis (AIA™)
14. Adaptive Nonlinear Static and Nonlinear Transient Analysis
15. Advanced Nonlinear Material Models (Hyperelastic, Nonlinear-Elastic, Plastic, Shape Memory, Brittle, Thermoelastic, etc.)
16. Special Nonlinear Elements (Tension-only Shell and Cable Elements, Shock Mount)
17. Nonlinear Database Management and Restarting
18. Modal Database Management and Modal Filtering
19. Integrated Modal Assurance Criteria (MAC) and Modal Cross-Orthogonality (MXO)
20. Virtual Fluid Mass Boundary Element
21. Imported Results Data Interpolation
22. Automated Inertial Relief (AIR™)
23. Robust and Accurate Element Library
24. High Performance, Large Capacity Linear and Eigensolvers
25. Specialized Industry Features (DDAM, CMS, DMIG, etc.)



# 10 Reasons You Should Be Using NEi Nastran

## 1. High Performance

NEi Nastran has multiple high-performance sparse direct and iterative solvers built in. The PCGLSS solver is one of the fastest solvers on the market and is especially fast for large parabolic tetrahedron element (CTETRA) models which are common with most solid meshing modelers.

## 2. High End Analysis Modeler

Femap is tightly integrated with NEi Nastran and also provides integration to a wide range of industry-standard structural and thermal solvers.

## 3. DMAP Alternative

With NEi Nastran there is no need for tedious DMAP programming as most of the functionality traditionally reserved for DMAP is directly embedded and easy to use. Examples include a user accessible modal database and special productivity features for viewing, editing, and storing modal data.

## 4. Industry Specific Productivity Features

- Aerospace
  - Specialized nonlinear elements such as tension-only shell and cable elements
  - Load and boundary condition interpolation for mapping thermal and CFD output from heat transfer and fluid dynamic models to structural models for load and boundary condition definition
  - Extensive composite material support including, 2D orthotropic, 3D orthotropic, general anisotropic, laminate lay-up definitions, and a wide range of failure criteria including the new NASA LaRC02 criteria and sandwich facesheet stability analysis
  - Helius:MCT Ply Failure integration
- Automotive
  - Specialized industry-proven element technologies including hybrid quad and hex elements, surface and spot weld elements, and dissimilar mesh interpolation elements
  - Support for standard manufacturing process effects such as casting induced warpage and residual stress and strain
- Maritime
  - Specialized solution sequences that do not require tedious DMAP programming including Design Dynamic Analysis Method (DDAM), integration with Anteon's Underwater Shock Analysis (USA) program, and compatibility with MAESTRO from Proteus Engineering
  - Special modal filtering and database restart tools for performing DDAM and dynamic response solutions increase productivity by allowing a modal database to be altered and reused with rerunning an eigenvalue extraction analysis

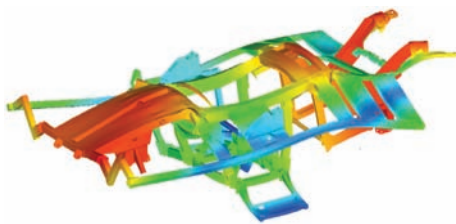

Modal Transient Response Analysis of an Automotive Frame: 3,163,596 DOF. Total Solution time: 1.6 hr. (75 modes) and 2.3 hr. (150 modes). Run on an Intel Core i7 2.8 GHz CPU with 8GB of RAM.

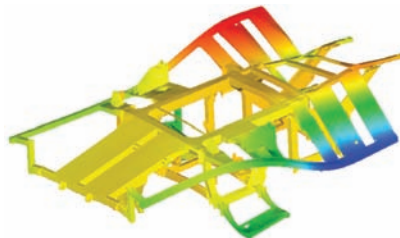

Modal Frequency Response Analysis of an Automotive Frame: 3,163,596 DOF. Total Solution time: 1.8 hr. (75 modes) and 2.4 hr. (150 modes). Run on an Intel Core i7 2.8 GHz CPU with 8GB of RAM.

## Customer Testimonial

"Finite Element Analysis has become an important tool to examine designs for their performance under load before a physical prototype exists. The two main advantages we gain through the use of FEA are: shorter time to market and optimized designs to avoid vibrations or to reduce weight and costs. After an extensive evaluation we decided to use NEi Nastran as our solver due to its high accuracy, robustness and productivity."

Thilo Trautwein  
ACES Engineering

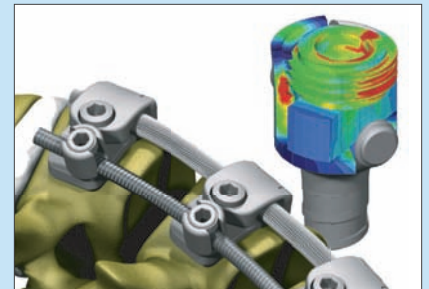
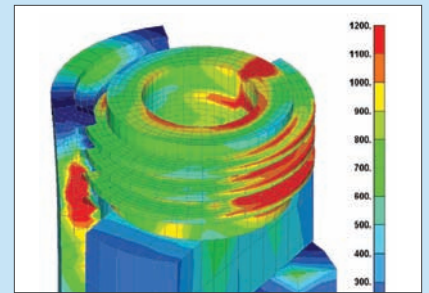

Utilizing the power of NEi Nastran, ACES was able to analyze not only the complex nonlinear material models, but the complete sliding contact between arbitrary surfaces including friction. Only three design and NEi Nastran analysis iterations were required to obtain a fail-safe screw, with adequate strength to withstand the anticipated spinal loads.

## Customer Testimonial

“We have chosen NEi Nastran after an extensive and detailed internal benchmark, comparing the results, the performance, and the features of the solver developed by NEi Software, Inc. with those of our former FEA platform. Full compatibility, accuracy, along with the professionalism and quick turnaround of the tech support from NEi Software and SmartCAE were the main reasons why we selected NEi Nastran as our FEA software for the future.”

Paolo Marabini  
Minardi F1 Team

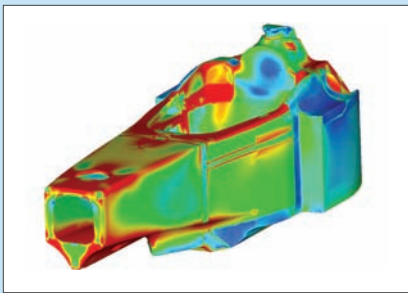

Minardi benefited from the use of NEi Nastran due to a reduced modeling time, surface contact feature, robustness of the nonlinear analysis setup and solution, accuracy (results compared well with test results), and seamless data access (input-output data generated by NEi Nastran and the previous Nastran package were shared without incompatibility issues).

## 5. Help Designed to Help

NEi Nastran's Cause, Action, Remarks formatted error and warning message help is designed to make it easy to diagnose and correct model errors quickly. All Nastran documentation is easily accessed through both context sensitive Windows help and Adobe .pdf file formats.

## 6. Advanced Nonlinear

NEi Nastran has many of the advanced features found in dedicated nonlinear analysis tools such as Abaqus. One such feature is support for true 3D surface contact which is not only very easy to setup but extremely robust.

## 7. Cost Effective

Controlling software costs is a major concern for all companies. Managers are under constant pressure to get the most out of their software budget. NEi Nastran provides better functionality and performance for significantly less cost when compared to other leading FEA products.

## 8. Better Support

At NEi Software, support is geared toward the individual engineer with quick turnaround on all requests. Whether your preference is to attend a training class at our facility, attend an online course, or obtain custom on-site training for the staff at your facility, NEi Software makes your software investment work for you by backing it up with the help you need when you need it.

## 9. Choice of CAD-integrated or CAD-independent FEA

NEi Fusion is CAD independent and imports all major CAD files. NEi Works provides SolidWorks users with an embedded, state-of-the-art finite element modeling tool. It features the familiar SolidWorks look and feel for all menus and functions, as well as an automatic mesh updating feature and FEA entity to geometry associativity.

## 10. NEi Nastran Editor

NEi Nastran includes a fully integrated and customizable Nastran Editor for controlling program operation, model editing, trade study generation, and results analysis. It is designed to increase productivity through easy access to model input data and results output, both graphical and tabular.

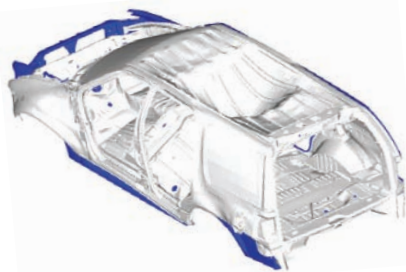

SUV Modal Analysis: 1,230,000 DOF. Total Solution time: 6.8 min. (20 modes) and 17 min. (100 modes). Run on an Intel Core i7 2.8 GHz CPU with 8GB of RAM.

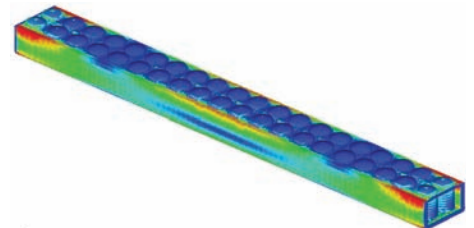

Cargo Ship Linear Static Analysis: 10,963,000 DOF. Total Solution time: 42 minutes. Run on an Intel Core i7 2.8 GHz CPU with 8GB of RAM.

# NEi Nastran Analysis Types

NEi Nastran provides analysis capabilities for the following solution types:

## Linear Static Analysis

- Linear stress, strain, deflection
- Inertial relief
- Thermal stress and deflection
- Prestress
- Mass properties
- Multiaxial

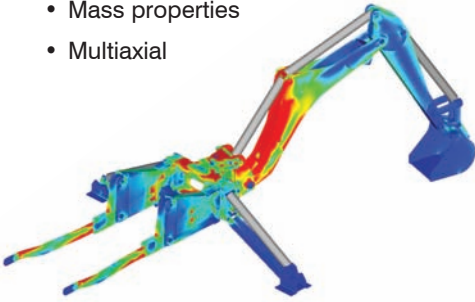

Linear Statics

## Dynamic Response

- Direct transient response
- Direct frequency response
- Modal transient response
- Modal frequency response
- Random vibration
- Modal response/shock spectrum generation
- Modal summation (ABS, SRSS, NRL, CQC, DDAM)
- Linear and nonlinear direct transient response
- Linear and nonlinear prestress support for all modal solutions
- Vibration fatigue

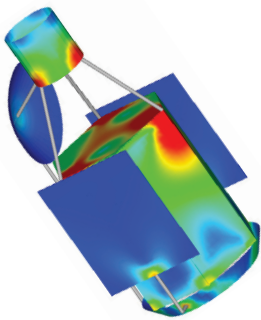

Transient Response

## Modal Analysis

- Natural frequencies and mode shapes
- Flexible and rigid body motion
- Modal participation factors, effective mass/weight, and reaction forces
- Linear and nonlinear prestress (stiffening)
- Virtual fluid mass

## Transient Heat Transfer

- Linear and nonlinear
- Conduction, convection, and radiation

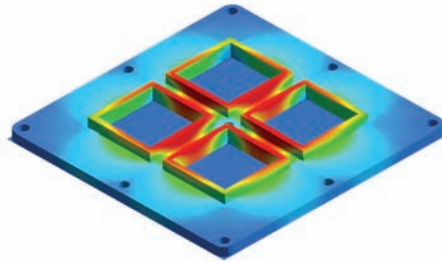

Linear Steady State Heat Transfer

## Steady State Heat Transfer

- Linear and nonlinear
- Conduction, convection, and radiation

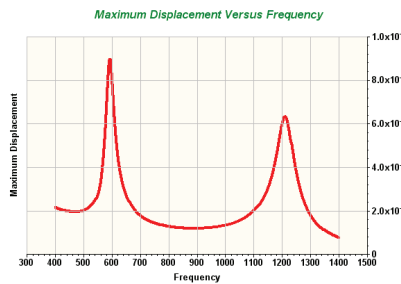

Frequency Response

## Customer Testimonial

“Cessna Aircraft is using NEi Nastran to analyze airframe components on the Citation CJ3 and the Citation Mustang. Cessna Engineers have been very impressed with the customer service received from NEi Software. The development of tension-only quad elements eliminates redundant models and repetitive work functions, resulting in reduced analysis cycle time.”

Gene Paulsen  
Cessna Aircraft



Cessna Aircraft Company of Wichita, Kansas used NEi Nastran to perform finite element analysis on the new Citation CJ3 and Citation Mustang business jets. Customer driven enhancements like the Tension-Only Quad Element allowed Cessna to avoid redundant models and repetitive work function resulting in reduced analysis cycle time.



## Customer Testimonial

“Composites analysis is inherently complex and challenging. Choosing the right FEA software provider becomes that much more important. Six years of experience with NEi Nastran advanced software features coupled with superb service and support has confirmed my choice.”

Phil Craven  
America's Cup Composites Analyst

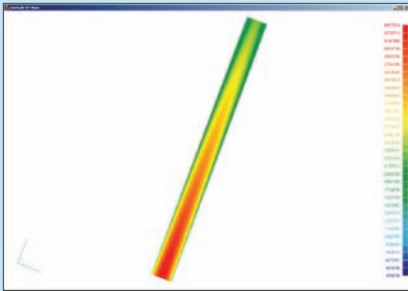

NEi Nastran users design, analyze and optimize their designs early in the development cycle. NEi Software technical support is there also to help them get the most out of structural, fluid dynamic and advanced composite modules. They get things right when it's time to build. They push the envelope... without breaking.

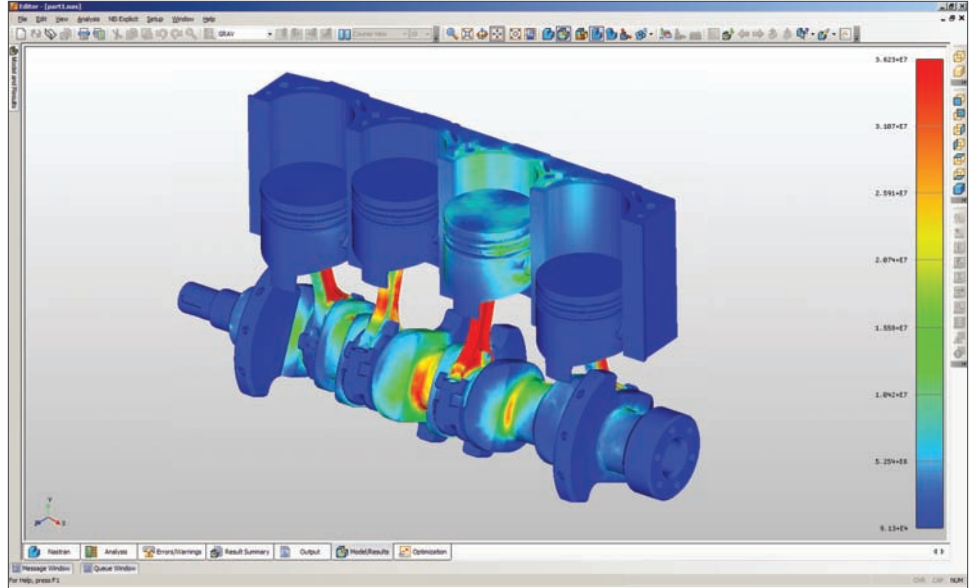

Nonlinear transient analysis of an engine block with large displacements, rotations and surface contact

## Buckling Analysis

- Critical loads and mode shapes
- Linear and nonlinear initial stress

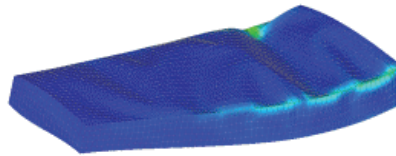

Buckling

## Nonlinear Analysis

- Nonlinear static and transient response
- Large displacement and rotation
- Automated Impact Analysis (AIA™)
- Material nonlinear (nonlinear elastic, elastic-plastic, perfectly plastic thermo-elastic, visco-elastic, creep)
- Tension only (cables and shell elements)
- Contact (gap, slide line, and surface to-surface, all with friction)
- Progressive Ply Failure Analysis (PPFA™)
- Brittle materials (concrete)
- Shape memory materials (Nitinol)

## General (supported in all solutions)

- Composite laminate materials
- Temperature dependent materials
- Direct matrix import and export (DMIG)
- Craig-Bampton and Guyan reduction
- Superelement support
- Displacement, load, and temperature interpolation

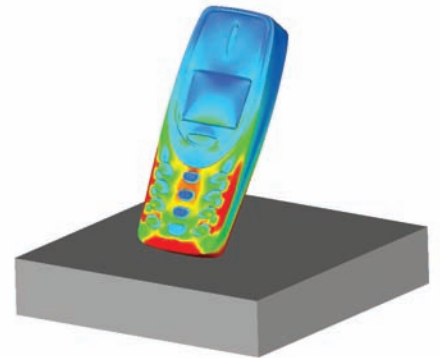

Automated Impact Analysis (AIA) can also be used as a virtual Drop Test as in the case of this cell phone.

---

## About NEi Software

NEi Software is a world leader in Finite Element Analysis (FEA), engineering simulation, and virtual test software. The core product NEi Nastran is a powerful, industry-proven FEA solver that thousands of companies routinely use to perform linear and nonlinear structural stress, dynamics, and heat transfer analysis. In addition, NEi Software's portfolio includes products for impact, kinematics, fatigue, acoustics, optimization, aeroelasticity, and Computational Fluid Dynamics (CFD) with support for a full range of materials from composites to hyperelastic rubber. NEi Software covers the different needs of each stage of the product development process, from designers looking for affordable, easy-to-use, CAD-based simulation for validation and trade-off studies to dedicated FE analysts looking for high accuracy, productivity, and real world fidelity. The website features case studies in aerospace, automotive, maritime, military, civil, petroleum, medical, and consumer products with videos, webinars, tutorials, and options for evaluation.

### Global Headquarters

5555 Garden Grove Blvd. Ste 300  
Westminster, CA 92683-1886  
United States

Phone: +1 (714) 899-1220  
Fax: +1 (714) 899-1369  
E-mail: [info@neisoftware.com](mailto:info@neisoftware.com)  
Website: [www.NEiSoftware.com](http://www.NEiSoftware.com)

### NEi Software EMEA Office

The Old Barrel Store  
Draymans Lane, Marlow  
Buckinghamshire, SL7 2FF  
United Kingdom

Phone: +44 (0)1628-400645  
Fax: +44 (0)1628-891701  
E-mail: [emea@neisoftware.com](mailto:emea@neisoftware.com)  
Website: [www.NEiSoftware.com/emea](http://www.NEiSoftware.com/emea)

### NEi Software Asia Office

Shinjuku Park Tower  
N30th Floor 3-7-1 Nishi-Shinjuku  
Shinjuku-ku, Tokyo, 163-1030  
Japan

Phone: +81-(0)3-5326-3062  
Fax: +81-(0)3-5326-3001  
Email: [asia@neisoftware.com](mailto:asia@neisoftware.com)



NEi, NEi Works, NEi Fusion, and the NEi logo are trademarks of NEi Software, Inc. Nastran is a registered trademark of NASA. All other trademarks are the property of their respective owners. Copyright © NEi Software, Inc. 2010. All rights reserved.

BROCNAST20100520